

DETALLE DE RETORNO DE VAPOR 2 DE VENTEOS A TANQUES

SIN ESCALA ACOT.: CMS.

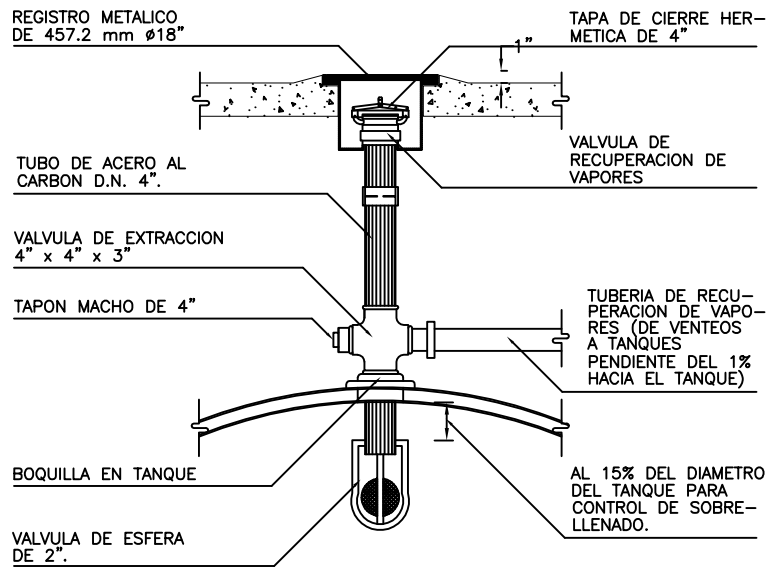

CORTE ESQUEMATICO SIN ESCALA ACOT.: CMS.

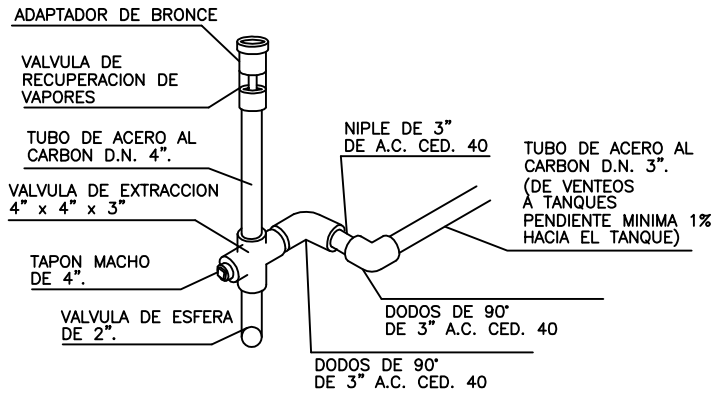

DETALLE DE BOMBA SUMERGIBLE
RETORNO DE VAPOR DE
DISPENSARIOS A TANQUES
 SIN ESCALA ACOT.: CMS.

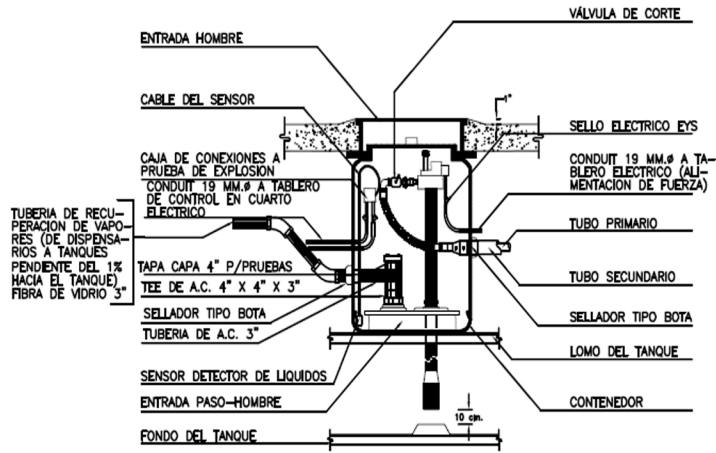
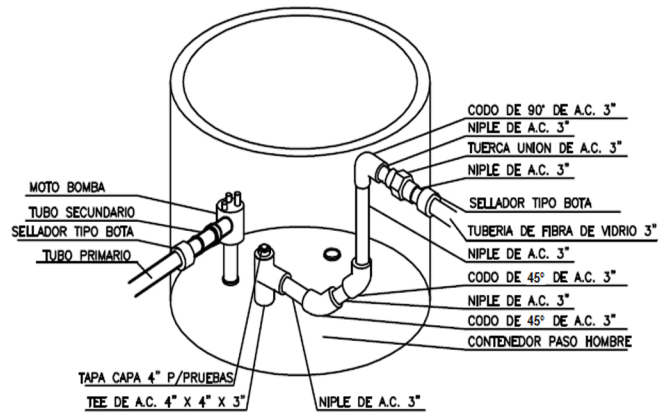

CORTE ESQUEMÁTICO
 SIN ESCALA ACOT.: CMS.



DETALLE DE VENTEOS

3 GASOLINA Y DIESEL

SIN ESCALA

ACOT.: CMS.

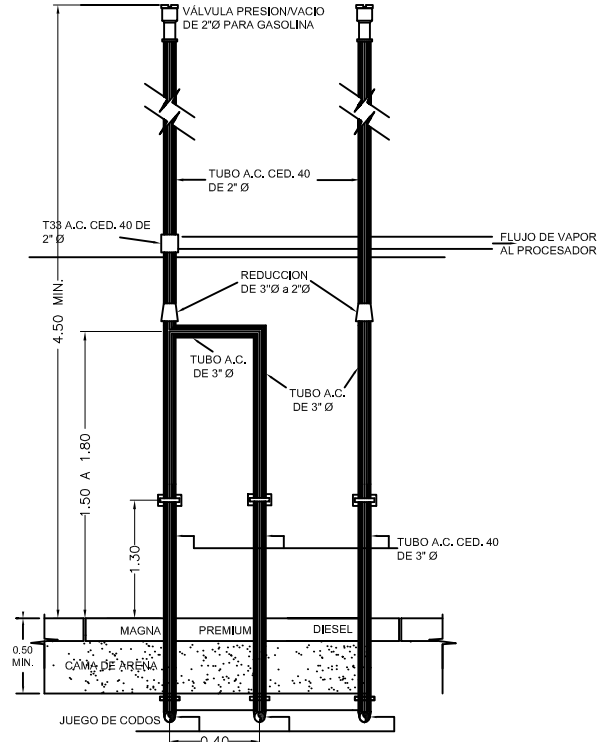
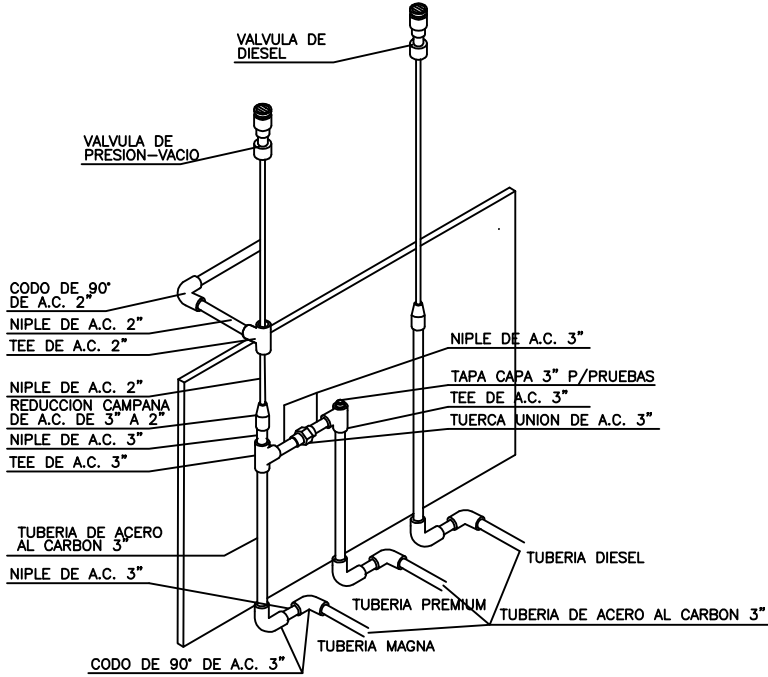

CORTE ESQUEMATICO
SIN ESCALA ACOT.: CMS.

